



# GASTRO BUFFET MUSIC



 **ENOFRIGO**<sup>®</sup> srl



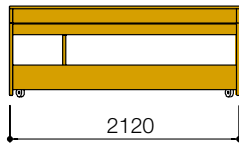
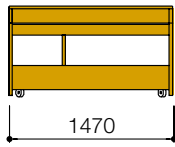

TANGO RF-2000

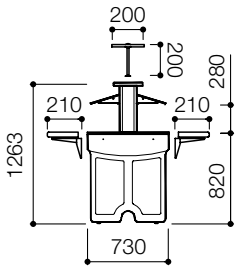

TANGO-RF



OPTIONAL

TANGO RF-1400

# TANGO



OPTIONAL

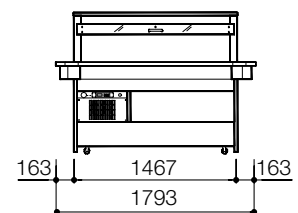
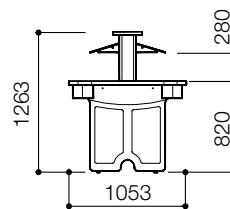
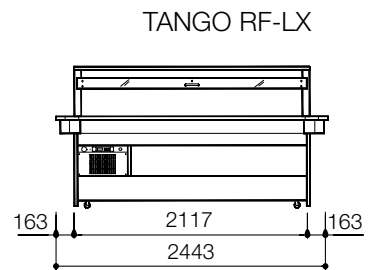
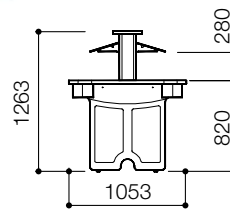

TANGO RF-LX-2000

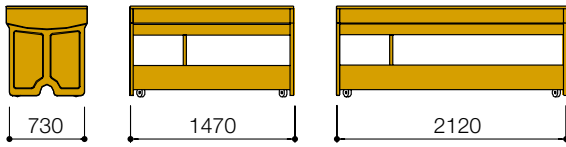

# TANGO

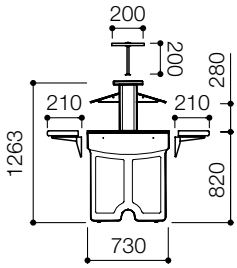

TANGO-BM



OPTIONAL

TANGO-BM-2000



OPTIONAL



S

Noce scuro  
Nußbaum dunkel  
Dark Walnut  
Noyer Foncé  
Nogal oscuro

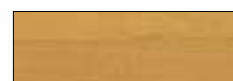

C

Rovere chiaro  
Eiche hell  
Pale Oak  
Rouvre clair  
Roble claro



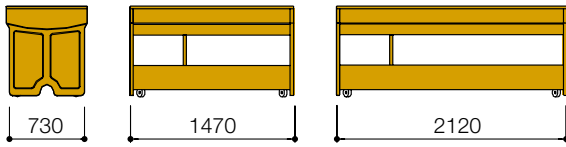

# BOLERO



BOLERO-RF-2000





# BOLERO

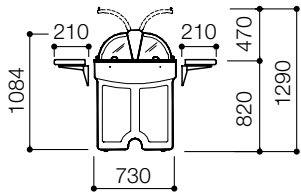

BOLERO-RF

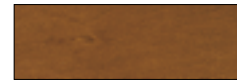

S

Noce scuro  
*Nußbaum dunkel*  
Dark Walnut  
*Noyer Foncé*  
Nogal oscuro



C

Rovere chiaro  
*Eiche hell*  
Pale Oak  
*Rouvre clair*  
Roble claro



BOLERO-RF-1400

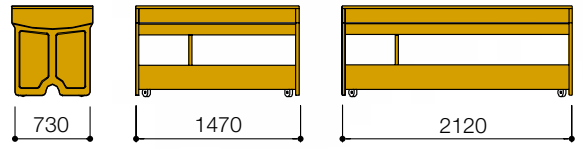

BOLERO-RF-2000



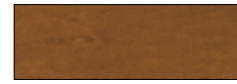
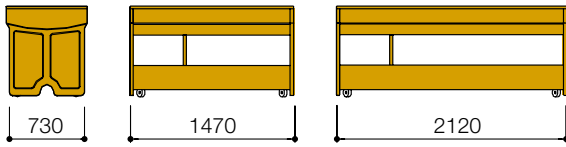

S

Noce scuro  
*Nußbaum dunkel*  
 Dark Walnut  
 Noyer Foncé  
 Nogal oscuro



C

Rovere chiaro  
*Eiche hell*  
 Pale Oak  
 Rouvre clair  
 Roble claro

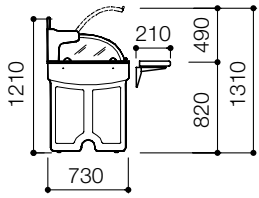

MAMBO-RF



MAMBO-RF-1400

# MAMBO

MAMBO RF-2000



MAMBO-RF-2000

# RUMBA

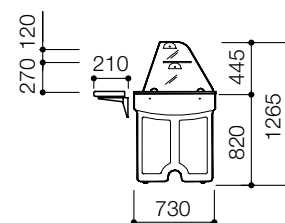

RUMBA-BM

RUMBA-BM-1400



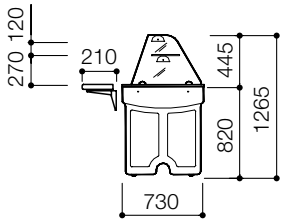

RUMBA-RF

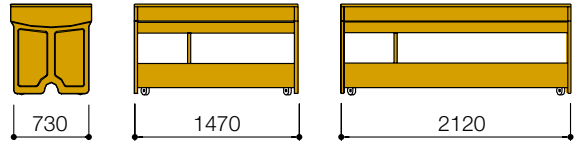

RUMBA-RF-2000



S

Noce scuro  
*Nußbaum dunkel*  
 Dark Walnut  
*Noyer Foncé*  
 Nogal oscuro

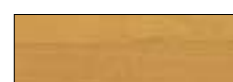

C

Rovere chiaro  
*Eiche hell*  
 Pale Oak  
*Rouvre clair*  
 Roble claro



RUMBA





# NEUTRAL



S

Noce scuro  
*Nußbaum dunkel*  
Dark Walnut  
*Noyer Foncé*  
Nogal oscuro



C

Rovere chiaro  
*Eiche hell*  
Pale Oak  
*Rouvre clair*  
Roble claro



NEUTRAL 2000-B

NEUTRAL 1400-A

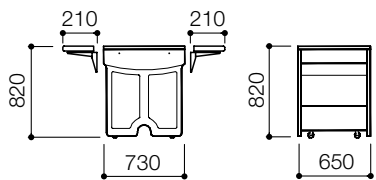

ELEMENTO UNION

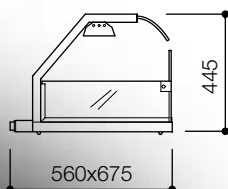
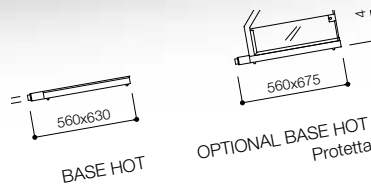
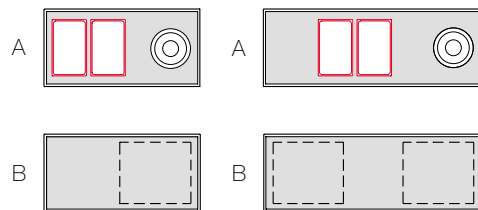
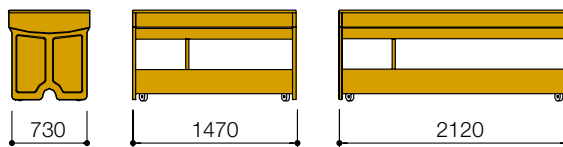

OPTIONAL BASEHOT  
Protetta

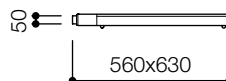

OPTIONAL BASEHOT

SAMBA



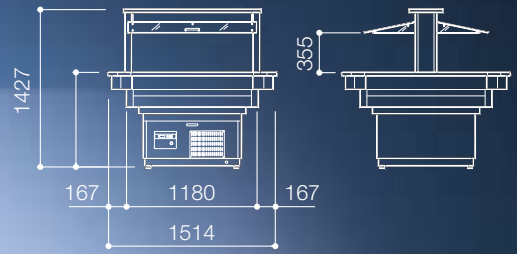

SAMBA-RF-VT-LX



# SAMBA

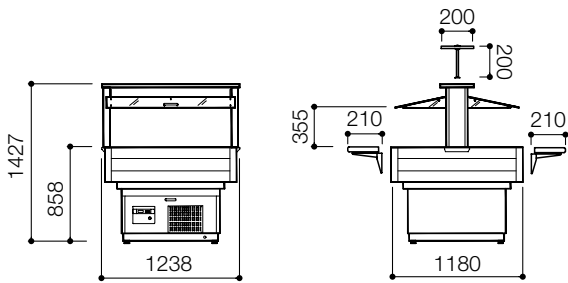

S

Noce scuro  
*Nußbaum dunkel*  
 Dark Walnut  
*Noyer Foncé*  
 Nogal oscuro



C

Rovere chiaro  
*Eiche hell*  
 Pale Oak  
*Rouvre clair*  
 Roble claro

SAMBA-RF-VT

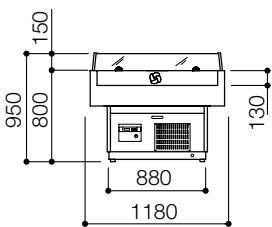

SAMBA RF VT PROMOTION

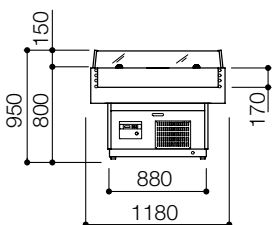

SAMBA RF ST PROMOTION

SAMBA-RF-VT-PROMOTION

# COMPONIBILITÀ



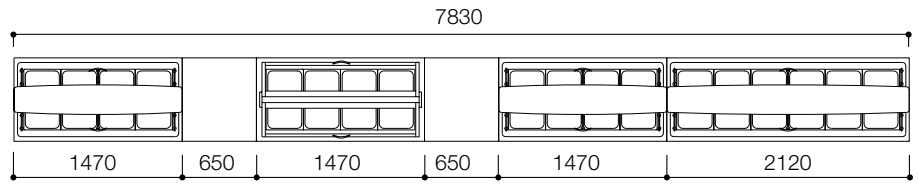





REFRIGERATO

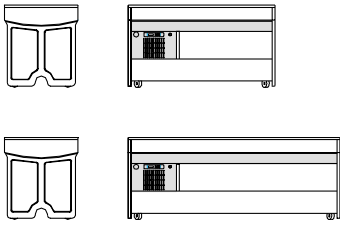

BAIN MARIE

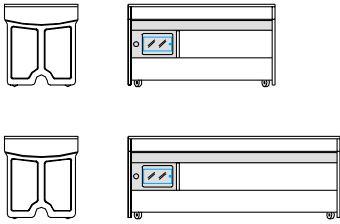

NEUTRAL

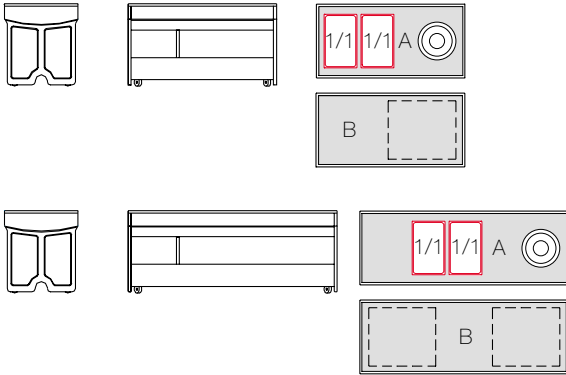

ELEMENTO UNION

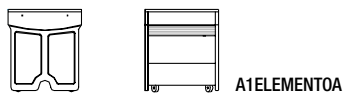

SAMBA-RF-VT   
A1SAMBA

SAMBA-RF-VT-LX   
A1SAMBALX

SAMBA-RF-VT PROMOTION   
A1SAMBAPRO

KIT REFRIGERATO

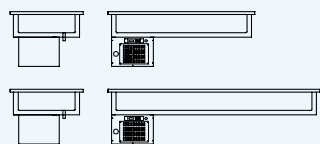

KIT BAIN MARIE

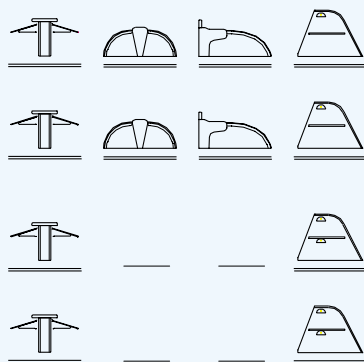
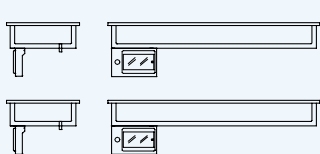

TANGO-RF A1TANGORF14  
TANGO-RF-LX A1TANGORFLX14  
BOLERO-RF A1BOLERORF14  
MAMBO-RF A1MAMBORF14  
RUMBA-RF A1RUMBARF14

TANGO-RF A1TANGORF20  
TANGO-RF-LX A1TANGORFLX20  
BOLERO-RF A1BOLERORF20  
MAMBO-RF A1MAMBORF20  
RUMBA-RF A1RUMBARF20

TANGO-BM A1TANGOBM14  
TANGO-BM-LX A1TANGOBMLX14  
RUMBA-BM A1RUMBABM14

TANGO-BM A1TANGOBM20  
TANGO-BM-LX A1TANGOBMLX20  
RUMBA-BM A1RUMBABM20

NEUTRAL A1NEUTRALA14  
A1NEUTRALB14  
TANGO A1TANGO14  
A1TANGOB14  
TANGO-LX A1TANGOLXA14  
A1TANGOLXB14  
RUMBA A1RUMBAA14  
A1RUMBAB14

NEUTRAL A1NEUTRALA20  
A1NEUTRALB20  
TANGO A1TANGO20  
A1TANGOB20  
TANGO-LX A1TANGOLXA20  
A1TANGOLXB20  
RUMBA A1RUMBAA20  
A1RUMBAB20

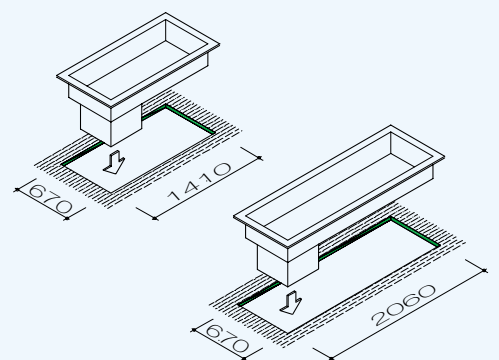
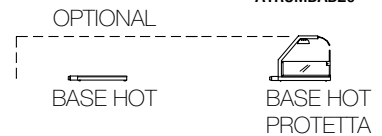

Mobili / Mobil / Cabinets Mobilier / Muebles		Dati tecnici / Technische Daten / Technical data / Données Techniques / Datos Técnicos				
		Potenza elettrica / Stromaufnahme Electrical rating / Puissance électrique Potencia eléctrica (Lampade, Lampen, Lampas, Lampes, Lámparas)	Potenza frigorifera / Leistung Refrigeration power Puissance frigorifique Potencia frigorífica (-10°C ÷ +45°C)	Gas refrigerante Refrigerating gas Gas réfrigérant Kühlung Gas refrigerante	Temperatura di esercizio Betriebstemperatur Working temperature Température de travail Temperatura de trabajo (Ta = +25°C / U.R. = 60%)	Dimensioni e peso apparecchio con cartone Ausmaßen und Gewicht des Geräts mit Karton Appliance dimensions and weight with carton Poids et dimensions appareil avec carton Dimensiones y peso mueble con carton
Model		Watt	Watt (kcal/h)	HFC	C°	A-BxH Kg
REFRIGERATO	<b>Tango - RF</b>	435 1x36 464 1x58	510W 440kcal 510W 440kcal	R404A R404A	+2 +7°C +2 +7°C	760x1540x1400 197 760x2200x1400 260
	<b>Tango - RF - LX</b>	435 1x36 464 1x58	510W 440kcal 510W 440kcal	R404A R404A	+2 +7°C +2 +7°C	760x1540x1400 245 760x2200x1400 312
	<b>Bolero - RF</b>	435 1x36 464 1x58	510W 440kcal 510W 440kcal	R404A R404A	+2 +7°C +2 +7°C	760x1540x1400 172 760x2200x1400 227
	<b>Mambo - RF</b>	435 1x36 464 1x58	510W 440kcal 510W 440kcal	R404A R404A	+2 +7°C +2 +7°C	760x1540x1400 183 760x2200x1400 242
	<b>Rumba - RF</b>	435 1x36 464 1x58	510W 440kcal 510W 440kcal	R404A R404A	+2 +7°C +2 +7°C	760x1540x1400 184 760x2200x1400 236
BAIN MARIE	<b>Tango - BM</b>	3000 4X150 4600 6X150			+30 +80°C +30 +80°C	760x1540x1400 173 760x2200x1400 244
	<b>Tango - BM - LX</b>	3000 4X150 4600 6X150			+30 +80°C +30 +80°C	760x1540x1400 214 760x2200x1400 280
	<b>Rumba - BM</b>	3000 4X150 4600 6X150			+30 +80°C +30 +80°C	760x1540x1400 169 760x2200x1400 220
	<b>Neutral</b>	1400 2000				760x1540x850 89 760x2200x850 121
	<b>Neutral Tango</b>	1400 1X36 2000 1X58				760x1540x1400 128 760x2200x1400 190
	<b>Neutral Tango - LX</b>	1790 1X36 2240 1X58				760x1540x1400 164 760x2200x1400 241
	<b>Neutral Rumba</b>	1400 1X36 2000 1X58				760x1540x1400 116 760x2200x1400 166
	<b>Base Hot</b>	800			+30 +80°C	690x645x75 15
	<b>Base Hot protetta</b>	800 2X150			+30 +80°C	715x645x475 28
REFRIGERATO	<b>Samba - RF - VT</b>	920 2X30	710W 610kcal	R404A	+2 +7°C	1450X1340X1440 208
	<b>Samba - RF - VT - LX</b>	920 2X30	710W 610kcal	R404A	+2 +7°C	1450X1340X1440 251
	<b>Samba - RF - VT promotion</b>	920	710W 610kcal	R404A	+2 +7°C	840X1340X1440 179
	<b>Samba - RF - ST promotion</b>	435	510W 440kcal	R404A	+6 +8°C	840X1340X1440 179
EL UNION	<b>Elemento Union</b>					760x630x950 50

Alimentazione: [220-240V 50Hz]. Disponibili su richiesta [220-240V 60Hz] e [115V 60Hz]. / Stromart [220-240V 50Hz]. Vorhanden nach Wunsch [220-240V 60Hz] und [115V 60Hz].  
Electrical supply [220-240V 50Hz]. Available on request [220-240V 60Hz] e [115V 60Hz]. / Alimentation [220-240V 50Hz]. Disponible sur demande [220-240V 60Hz] e [115V 60Hz].  
Alimentación [220-240V 60Hz]. Disponible sobre pedido [220-240V 60Hz] e [115V 60Hz].

Colori: noce scuro; rovere chiaro, bianco, grezzo (per consentire abbinamenti diversi). / Farben: nußbaum dunkel, heiche hell, weiss lackiert, ungebeizt.  
Colours: dark walnut, pale oak, white laquered, unpainted. / Couleurs: bois foncé, rouvre clair, laqué blanc, pas verni. / Colores: nogaloscuro, roble claro, blanco, no acabado.

## Accessori a richiesta

Vaschette gastronorm  
Piani inox rialzati (cm 6 e cm 15)  
Kit cassetoni (cm 140 e cm 200)  
Piani perimetrali (già inclusi nei modelli Luxus)  
Colori speciali ral  
Controvasca inox  
Base hot cm 63  
Mensola superiore in cristallo (solo serie Tango-Samba)

## Optionals

Gastronorm pans  
Inox false bottoms (cm 6 and cm 15)  
Drawers kit (cm 140 and cm 200)  
Peripheral shelves  
(already standard included in Luxus models)  
Special colours (ral)  
Double inox tank  
Hot plate cm 63  
Upper crystal shelf (Tango-Samba series only)

## Sonderzubehör

Gastronorm einsätze  
Angehobene falsche edensthalablagen  
(cm 6 und cm 15)  
Reserveshubladen kits (cm 140 und cm 200)  
Tablettruschen für platten  
(schon dabei in Luxus Modelle)  
Spezielle Farben (ral)  
Edensthal Doppelboden  
Heisse Platte cm 63  
Obere Kristallkonsolle (nur Tango-Samba Serien)

## Accessoires

Bacs gastronorm  
Faux fonds inox (cm 6 et cm 15)  
Kit tiroirs (cm 140 et cm 200)  
Supports plats (standard pour modèles Luxus)  
Couleurs spéciales (ral)  
Double cuve en inox  
Plaque chauffante cm 63  
Console supérieure en cristal  
(série Tango-Samba seulement)

## Accesorios

Contenedores gastronorm  
Falsos fondos inox (cm 6 y cm 15)  
Kit de cajones (cm 140 y cm 200)  
Estantes plegable perimetral  
(ja incluidos en los modelos Luxus)  
Colores especiales (ral)  
Tanque removible inox  
Placa caliente cm 63  
Cristal superior de protección de platos  
(solo serie Tango-Samba)



Le riproduzioni di questo catalogo possono non corrispondere esattamente alle versioni commercializzate perché soggette alle norme in vigore in ciascun paese di destinazione. La ENOFRIGO Srl si riserva di apportare modifiche alla costruzione ed alla dotazione dei mobili senza alcun obbligo di preavviso

Any reproduction of this catalogue may not correspond exactly to the commercialised versions since they are subject to laws and regulations in force in different countries. ENOFRIGO Srl claims the right to introduce changes in manufacturing process and units equipment without prior notice.

Die Bilder dieser Brochure können manchmal den vermarkten Versionen nicht völlig entsprechen, wobei Sie an gültigen Normen und Gesetzen von verschiedenen Länder anpassen sollen. ENOFRIGO Srl behält sich mögliche Änderungen an Bauweise und Ausstattung der Modellen ohne vorherige Mitteilung vor.

Les reproductions de ce catalogue peuvent être non correspondantes aux modèles commercialisés, parce que elles sont sujettes aux lois en vigueur dans chaque pays de destination. ENOFRIGO Srl se réserve le droit d'apporter toutes modifications utiles sans préavis.

Cualquier reproducción de este catálogo puede no corresponder exactamente a la versión comercializada, puesto que los productos están conforme a leyes y regulaciones en vigor en diversos países. ENOFRIGO S.r.l. demanda las derechos de introducir cambios en el equipo y en el proceso de fabricación de los equipos sin aviso anterior.



## **Gastro Buffet MUSIC Refrigerati – Bain Marie – Neutri**

I vantaggi di questa linea di nuovissima concezione tecnica ed estetica:

Le vasche sono realizzate in acciaio inox Aisi 304, con cornice superiore a perimetro totale e complete di valvola di scarico condensa e vaschetta interna di raccolta acqua. I sistemi di raffreddamento e riscaldamento delle vasche sono esterni alla vasca stessa, per maggiore efficacia e migliore igiene. Grazie all'avanzata innovazione tecnologica di progettazione e realizzazione, esse si possono pulire perfettamente con la massima facilità.

I modelli Refrigerati sono controllati da termometro/termostato elettronico.

I modelli Bain Marie dispongono di un completo quadro comandi con termostato, oltre ad un interruttore magneto-termico salvavita di protezione.

Le resistenze elettriche a basso consumo e la particolare tecnica costruttiva permettono la continuità di funzionamento anche in caso di mancanza d'acqua senza alcun rischio.

I modelli Neutri sono disponibili anche con piano attrezzato con Gastronorm e cilindro sollevatore piatti.

Gli elementi modulari Union, realizzabili anche su disegno, permettono sviluppi lineari di varie configurazioni. Tutti i buffet sono dotati di ruote, di cui due munite di freno meccanico.

La struttura di tutti i mobili è in legno massiccio, di spessore fino a 30 mm, verniciato di colore noce scuro o rovere chiaro ed, a richiesta, altre colorazioni RAL per particolari personalizzazioni.

Le chiusure superiori dei buffet utilizzati "normalmente aperti", sono realizzate con cristalli in vetro temperato infrangibile e dotate di un'originale e **BREVETTATO** sistema

di sollevamento/abbassamento "one touch", scorrevole su cuscinetti e guide laterali, che può essere azionato con un solo dito.

Lampade fluorescenti assicurano l'illuminazione dei buffet, senza mai venire a contatto col cibo. I modelli Bain Marie utilizzano lampade alogene illuminanti e riscaldanti.

La gamma di base dei buffet è completata da accessori optional, quali:

- Mensole perimetrali ribaltabili - Cassettone porta-piatti di capacità 30 kg. - Cristallo superiore di protezione piatti.

I Gastro buffet **ENOFRIGO Music** consentono di rispettare le norme di igiene e temperatura previste dalla **direttiva Europea 93/43/CEE HACCP**, recepita ed attuata dal Governo Italiano con Decreto Legislativo 26/05/97 n. 155, e successivo aggiornamento del 18/01/2000. ( G.U. n.13 ).

## **Salad bars MUSIC Refrigerated – Bain Marie – Neutral**

The highlights of this line of a really new technical and esthetical conceiving:

The tanks are built in Aisi 304 stainless steel with shelf upper rim, standard fitted with condensation drain and inner water trap. Thanks to the innovative design and manufacturing system, the tanks can be perfectly cleaned.

Refrigerated models are controlled by an electronic thermostat/thermometer.

Bain-marie models are equipped with a control board with thermostat and include a thermomagnetic circuit breaker.

The low consumption electrical resistances and the special building technology, guarantee full functionality even in case of lack of water, without any risk.

Neutral models are also available with upper board equipped with GN pans and hoisting cylinders for dishes.

Union Modular elements can be manufactured as for drawings, for developments of various configurations. All salad bars are equipped with castors, two of which have brakes.

The frame structure of all pieces is in solid wood of thickness up to 30 mm., painted in dark walnut or pale oak colours. On request, other RAL colours for special personalization can be accepted.

Closing canopies of salad bars used in "normally open" way, are made of tempered crystals and are equipped with an original and **PATENTED** "one touch" up and down system, on slideways with bearings, that can be operated with one finger only!

Fluorescent lights will guarantee perfect lighting of display area, without contact with food. Bain-marie models will use halogen lamps for lighting and heating at the same time.

Several accessories for base range of salad bars are available, such as:

- Foldable shelves - Plates holding box (max weight capacity 30 kg) - Upper plates protecting crystal

**ENOFRIGO Music** salad bars conform to hygiene and temperature control as for **European norm 93/43/CEE HACCP**.

## **Gastro Buffet MUSIC gekühlt – Bain Marie – neutral**

Die Hauptmerkmalen von dieser Linie, aus neueste technische und aesthetische Konzept:

Die Wannen, aus Nirosta Aisi 304, sind einstückig tiefgezogen, mit abgerundeten Kanten und obere Rahmen. Ablaufventil sowie eine Tawwasserschale ermöglichen eine komplette und sehr leichte Reinigung.

Die Kühl- bzw. Warmsysteme sind außer der Wanne montiert, um bessere Arbeitsweise und Hygiene zu garantieren.

Die gekühlte Möbel sind mittels einem elektronischen Thermometer/Thermostat regelbar.

Die Bain Marie sind mit einem Schalttafel eingerüstet, komplett mit Thermostat und Thermomagnethauptschalter. Die Heizkörper und eine besondere Aufbautechnik erlauben die ununterbrochene Arbeitsweise des Möbels auch ohne Wasser in der Wanne, ohne Risiko.

Die neutralen Modellen sind vorhanden auch mit G/N geeignete Fläche und Tellerspendercylinder.

Die Modulelementen Union können auch nach Zeichnung gebaut werden und ermöglichen geradlinigen Ausbauen mit verschiedenen Formen (Gestaltungen). Alle Buffets sind mit Rollen ausgestattet, zwei mit Bremsen.

Das Gehäuse aller Möbel besteht aus massivem Holz, bis zu 30 mm.dick, und es kann dunkel Walnuß oder Eiche hell, lackiert sein, oder nach Wunsch auch andere Bearbeitungen wie RAL Farbe möglich sind.

Die obere Abdeckungen von den „immer offenen“ Buffets sind aus Sekuritglas und mit einem original und **PATENTIERTEN** auf/zu System „one touch“, laufend auf Kugellager, das man mit ein einzigem Finger betrieben kann. Leuchtstofflampen versichern die Beleuchtung von den gekühlten Buffets, ohne das Essen zu berühren. Bei Bain Marie Möbel sind Halogenlampen, die sorgen Beleuchtung sowie zusätzliche Wärme.

Eine große Auswahl an Zubehör ergänzt alle Buffets, sowie:  
- Abklappbarer Tabletrutschen - Reserveschubladen mit 30 Kg. Fassungsvermögen - Zusätzliche Hartglasablagefläche für Teller und Geschirr.

Die Gastro-Buffets **ENOFRIGO Music** erlauben, die hygienischen und thermischen Normen von den **Europäische Richtlinie 93/43/CEE HACCP** zu beachten.

## **Gastro Buffets MUSIC Réfrigérés – Bain Marie – Neutres**

Les point forts de cette ligne de conception technique et esthétique très nouvelle:

Les bacs sont réalisés en acier inox AISI 304 avec corniche supérieure à périmètre total, équipés de vanne de vidange de l'eau de condensation et de cuvette intérieure de récolte d'eau. Grâce à l'innovation technologique de projet et de réalisation, on peut les nettoyer parfaitement avec la plus grande facilité

Les systèmes de refroidissement et chauffage du bac sont extérieurs au bac même, pour une plus grande efficacité et une hygiène plus performante.

Le modèles Réfrigérés sont contrôlés par un thermomètre-thermostat électronique.

Les modèles Bain-Marie disposent d'un tableau de contrôle, complété de thermostat et d'un interrupteur magnéto-thermique sauve-vie de protection .

Les résistances électriques à faible consommation et la technique spéciale de la construction permettent la continuité de fonctionnement même en cas de manque d'eau sans aucun risque.

Les modèles Neutres sont aussi disponibles avec le dessus équipé de bacs G.N. et cylindre releveur d'assiettes.

Les éléments modulaires Union, réalisables même sur dessin, permettent des développements linéaires de plusieurs configurations. Tous les buffets ont quatre roues, dont deux dotées de freins mécaniques.

La structure de tous les meubles est en bois massif, d'épaisseur jusqu'à 30 mm., verni en couleur noyer foncé ou chêne clair et, sur demande, d'autres couleurs RAL pour personnalisations.

Les fermetures supérieures des buffets utilisés "normalment ouverts" sont réalisées en cristaux de verre trempé incassable et dotées d'un nouveau système **BREVETÉ** de relevage/fermeture "one touch", coulissant sur des paliers à billes, qui peut être actionné d'un seul doigt.

Des lampes fluorescentes assurent l'éclairage des buffets, sans venir jamais en contact avec le mets. Les modèles Bain Marie utilisent des lampes halogènes éclairantes et chauffantes.

La gamme de base des buffets est complétée par des accessoires optionnels, tels que:

- Tablettes périmétrales escamotable.  
- Grand tiroir porte-plat de capacité: 30 kg  
- Cristal supérieur de protection plats.

Les Gastro Buffets **ENOFRIGO Music** permettent de respecter les normes d'hygiène et de température prévues par la **Directive Européenne 93/43/CEE HACCP**.

## **Gastro Buffets MUSIC Refrigerados – Bain Marie – Neutros.**

Las ventajas de esta línea de nueva concepción técnica y estética:

Las cubas, totalmente en acero inox Aisi 304, con marco superior a perimetro total y dotadas de valvula de descarga condensado y cubetas interna por la recuperacion de la agua. Por la avanzada innovacion tecnologica de planteamiento y realizacion se pueden limpiar perfectamente con la maxima facilidad.

Los sistemas de enfriamiento y calefaccion de las cubas son al externo de la cuba, para mejor eficacia y mayor higiene.

Los modelos Refrigerados son controlados por un termómetro/termostato electrónico.

Los modelos Bain Marie tienen un completo tablero de mandos con termostato, mas de un interruptor magneto-termico salvavida de protección.

Las resistencias eléctricas de bajo consumo y la particular técnica constructiva permiten la continuidad de funcionamiento también en el caso de falta de agua sin algun riesgo.

Los modelos Neutros son disponibles también con plano dotado con Gastronorm y cilindro por el levantamiento de los platos.

Los elementos modulares Union, realizacion también de dibujo, permiten desarrollos lineales de varias configuraciones. Todos los buffets tienen ruedas, y dos están provistas de freno mecánico.

La estructura de todos los muebles es de madera maciza, espesor hasta 30 mm, barnizado de color nogal oscuro o roble claro y, a pedido, otras coloraciones RAL para particulares personificaciones.

Las cerrres superiores de los buffets "normalmente abiertos", son realizadas con cristales en vidrio templado, infrangible y dotadas de un original y **PATENTADO** sistema de

apertura/cierre "one touch" corredizo sobre almohadillas y guias laterales, que puede ser accionado con un solo dedo.

Lámparas fluorescentes garantizan la iluminacion de los buffets, sin nunca estar en contacto con la comida. Los modelos Bain Marie utilizan lámparas halógenas iluminantes y calentantes.

La gama de buffets es integrada de accesorios optional, como:

- Ménsulas perimétrico volquete - Cajón porta-platos con capacidad 30 kg. - Cristallo superior de protección platos

Los Gastro Buffets **ENOFRIGO Music** consenten de respetar las normas de higiene y temperatura correspondientes a la **Norma Europea 93/43/CEE HACCP**.

# GASTRO BUFFET MUSIC



I -35010 BORGORICCO (PD)

Via dell'Industria, 9/a

Tel. 049 5798041

Fax 049 5798806

[www.enofrigo.com](http://www.enofrigo.com)

E-mail: [info@enofrigo.com](mailto:info@enofrigo.com)